

CliniLever® CP-BS Lead Safe Hospital Basin Fixed Sets

PRODUCT CODES:

- 102.12.22.03
- 102.12.21.03
- 102.12.12.03
- 102.12.11.03
- 102.13.21.03
- 102.13.11.03
- 102.14.12.03

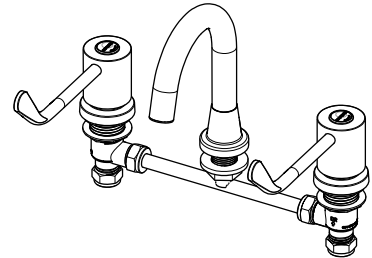

SPECIFICATIONS

- The CliniLever® product range is primarily used for hand washing applications in hospitals, aged care facilities, schools and in-home care.
- CliniLever® products provide state of the art features to comply with the latest healthcare guidelines.
- Easy to operate dual levers for on/off, hot and cold temperature control simplify hand washing procedures.
- All CliniLever® products provide laminar flow (not aerated).
- Our highly sought after lever design is easily operated with elbows or wrist to avoid hand contact.
- The main body is made of solid dezincification resistant (DR) brass rod, with a DR brass gooseneck outlet.
- Quick action SBA's includes brass jumper valve / ceramic cartridge component, with red and blue indicator button on 80mm or 150mm lever action handles.
- Lead Safe™ brass construction*

IMPORTANT: All CliniLever® healthcare taps are tested in accordance with AS/NZS 3718 and leave our premises in good working order.

*Our Lead Safe™ product range is compliant with the Lead-Free Requirements of the NCC 2022 Vol. Three, Clause A5G4(2) and NSF/ANSI 372.

** Any flow controller incorporated in the outlet to be tightened to prevent removal by hand. As Per AS3718.

WARNINGS: Special attentions to be paid on notes, photos, images, or drawings of assembly steps marked with the warning symbol.



TECHNICAL DATA

Inlet		½" CU/BSP
Outlet		Laminar Flow
Headwork	102.12.12.03, 102.12.11.03, 102.13.11.03	Jumper Valve
	102.12.22.03, 102.12.21.03, 102.13.21.03, 102.14.12.03	Ceramic Disc
Working Pressure Range (kPa)	Min	50
	Max	500
Working Temperature Range (°C)	Min	5
	Max	65
Nominal Flow rate (LPM)		5.5
Construction		Brass
Finish		Chrome
NOTE: Galvin Engineering continually strive to improve their products. Specifications may change without notice.		

TOOLS REQUIRED

- Power drill
- Spanner or adjustable crescent
- Copper tube cutter

PRE-INSTALLATION - MOUNTING DETAILS

- If the mounting holes do not already exist, mark out and drill the holes in the bench/trough to suit your requirements. The hole centres for the handles must be between 150mm and 255mm.
- Ensure the centre hole is equally spaced between the 2 larger holes

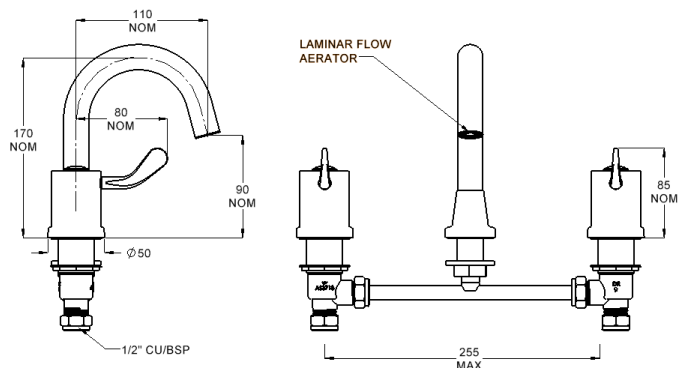
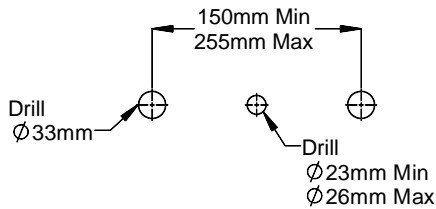

102.12.22.03/102.12.12.03/102.14.12.03

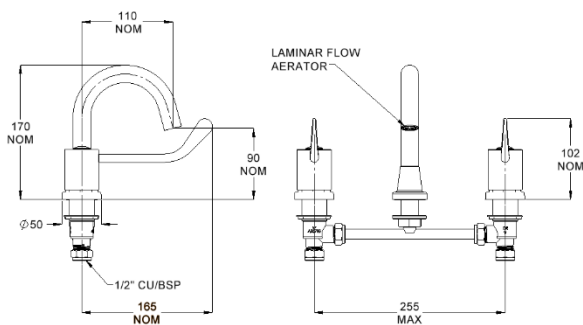

102.12.21.03/102.12.11.03

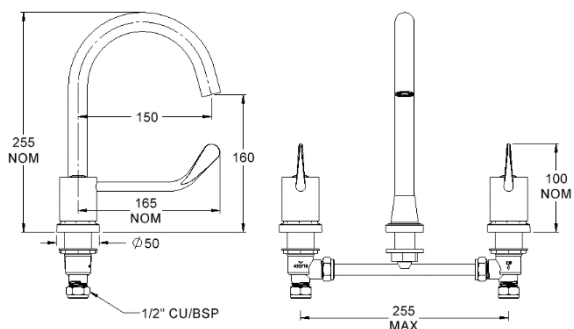

102.13.21.03/102.13.11.03

INSTALLATION

INSTALLATION COMPLIANCE: Galvin Engineering products must be installed in accordance with these installation instructions and in accordance with AS/NZS 3500, the PCA and your local regulatory requirements. Water and/or electrical supply conditions must also comply to the applicable national and/or state standards. Failing to comply with these provisions shall void the product warranty and may affect the performance of the product.

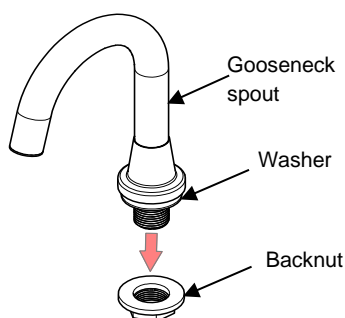

1. Fit Spout

- Fit the gooseneck spout into the bench.
- Ensure the sealing washer is placed underneath the base body.
- Position the spout to the front and secure underneath with supplied flanged backnut.
- Take care not to overtighten.

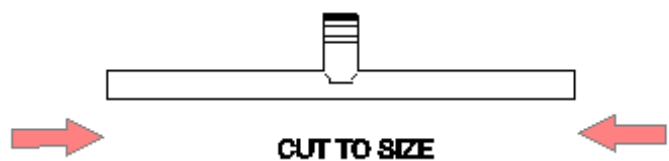

2. Cut copper breach

- Measure the distance between the basin body holes.
- Mark out the base copper tee using this measurement, subtracting 15mm from each end to allow for the basin body compression nuts.
- Ensure it is equal distance from the centre.

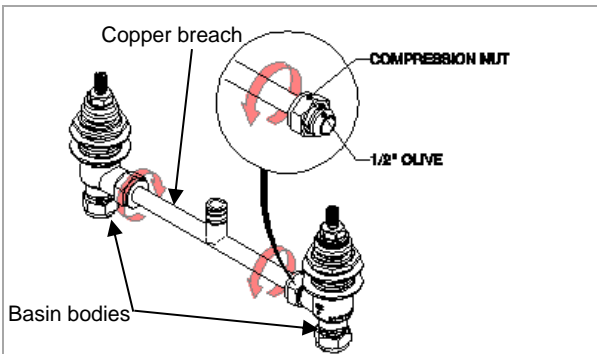

3. Fit basin bodies to copper breach

- Assemble basin bodies to the copper breach.
- Ensure the olive is positioned over the copper breach for sealing.
- Tighten the compression nut, taking care not to overtighten, as this may damage the olive.
- Ensure that the set is installed with hot and cold in the correct location. (i.e. J/V: Groove on the spindle assembly indicates hot).

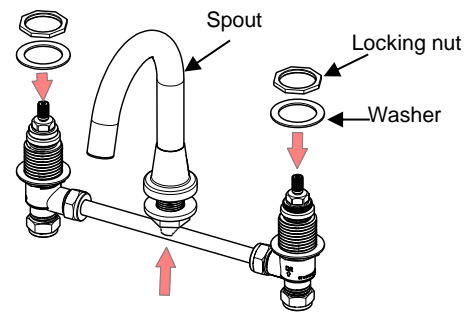

4. Fit basin body

- Insert the basin bodies and copper breach assembly up through the pre-cut holes.
- Centre the basin bodies.
- Carefully insert the copper breach outlet into the spout, to avoid damage to the tee O-rings.
- Secure in place with supplied washer and locking nut.

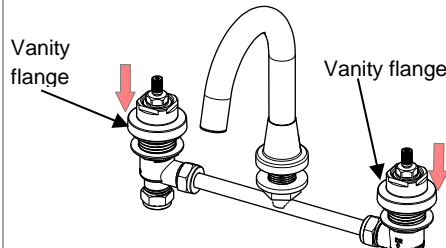

5. Fit basin/sink flange

- Tighten the vanity flange onto the threaded basin body.
- Take care not to overtighten.

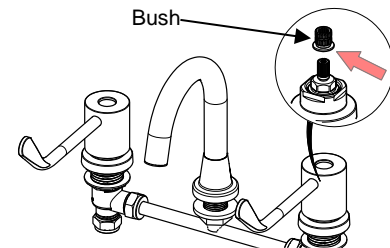

6. Locate handle

- When the spindle is in the closed position, firmly press the lever handle onto the spindle with levers facing forward.
- Check the handle operation. They should turn freely for a full 1/4 turn.

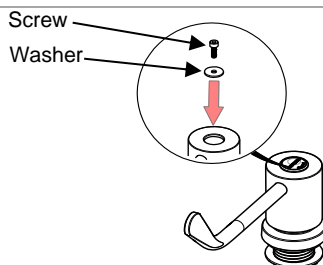

7. Fit handle

- Secure the handles in position using the supplied screws and washers.

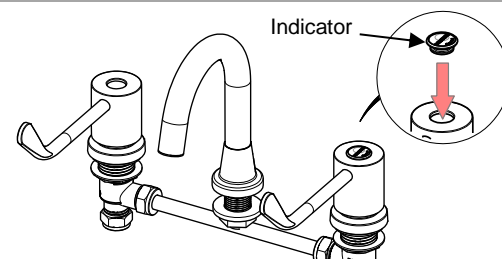

8. Fit water temperature indicator & testing

- Once the lever handles are secure, fit the appropriate water temperature indicators.
- Hot/warm on the left handle, cold on the right.
- Once secured, connect the hot and cold water.
- Open the lever handles and ensure that there is flow from both hot and cold inlets.
- Inspect the tap and check for any leaks.

TROUBLESHOOTING

PROBLEM	CAUSE	RECTIFICATION
Taps are dripping water	Jumper valves are worn or damaged	Replace jumper valve
	Ceramic discs are worn or damaged	Remove and inspect SBA. Remove debris and/or replace SBA if damaged.
	Tap seat is damaged	Refurbish tap seat using a reseating tool.
Water is leaking from spindle	O-ring on jumper valve spindle is damaged or worn	Replace O-ring
Water is not flowing from tap	Water is turned off	Turn water on
	Aerator or flow regulator is blocked by debris	Remove aerator and/or flow regulator from tap and remove debris. Install an inline strainer.
Spindle is difficult to turn (jumper valve)	Build up of scale on spindle, spindle worn or O-ring has been damaged	Remove jumper valve, clean and regrease. Replace O-ring. Complete SBA may need to be replaced.
Handle is loose	Screw has come loose	Tighten handle screw
Flange won't screw down onto basin/sink surface	Tap bodies are set too far out	Re-position tap bodies and breach piece

SERVICE AND MAINTENANCE

JUMPER VALVE TAPWARE	CERAMIC DISC TAPWARE
<ol style="list-style-type: none"> 1. Turn off the water supply and turn on the tap handle to drain water from the bodies. 2. Remove the temperature indicator from the handle. 3. Remove the handle from the tap. 4. Unscrew the top assembly from the body. 5. Check the O-ring on the spindle and the jumper valve for wear and damage. Replace if required. 6. Clean the spindle and body of debris. 7. Place a new O-ring (if required) onto the spindle and re-grease with potable water approved grease. 8. Re-assemble top assembly. Follow the product installation guidelines for the relevant product to re-assemble. 	<ol style="list-style-type: none"> 1. Turn off the water supply and turn on the tap handle to drain water from the bodies. 2. Remove the temperature indicator from the handle. 3. Remove the handle from the tap. 4. Unscrew the ceramic headpart from the body. 5. Check the O-ring on the ceramic headpart for wear and damage. Replace if required. 6. Clean the head part and the body of any debris. 7. Replace the cartridge and hand-tighten back into the body. 8. Follow the product installation guidelines for the relevant product to re-assemble.

WARRANTY

Galvin Engineering products are covered under our Manufacturer's Warranty. Galvin Engineering products must be installed in accordance with the installation instructions and in accordance with AS 3500 and NCC Volume Three, relevant Australian Standards and local authorities applicable to product being installed. Water and electrical supply conditions must also comply to the applicable national and/or state standards, failing to comply with these provisions may void the product warranty and affect performance of the product.

Please visit www.galvinengineering.com.au to view the full warranty, our Installation Compliance and Maintenance & Cleaning information as well as any other additional information.